

LONGMILL 30X30 TABLE

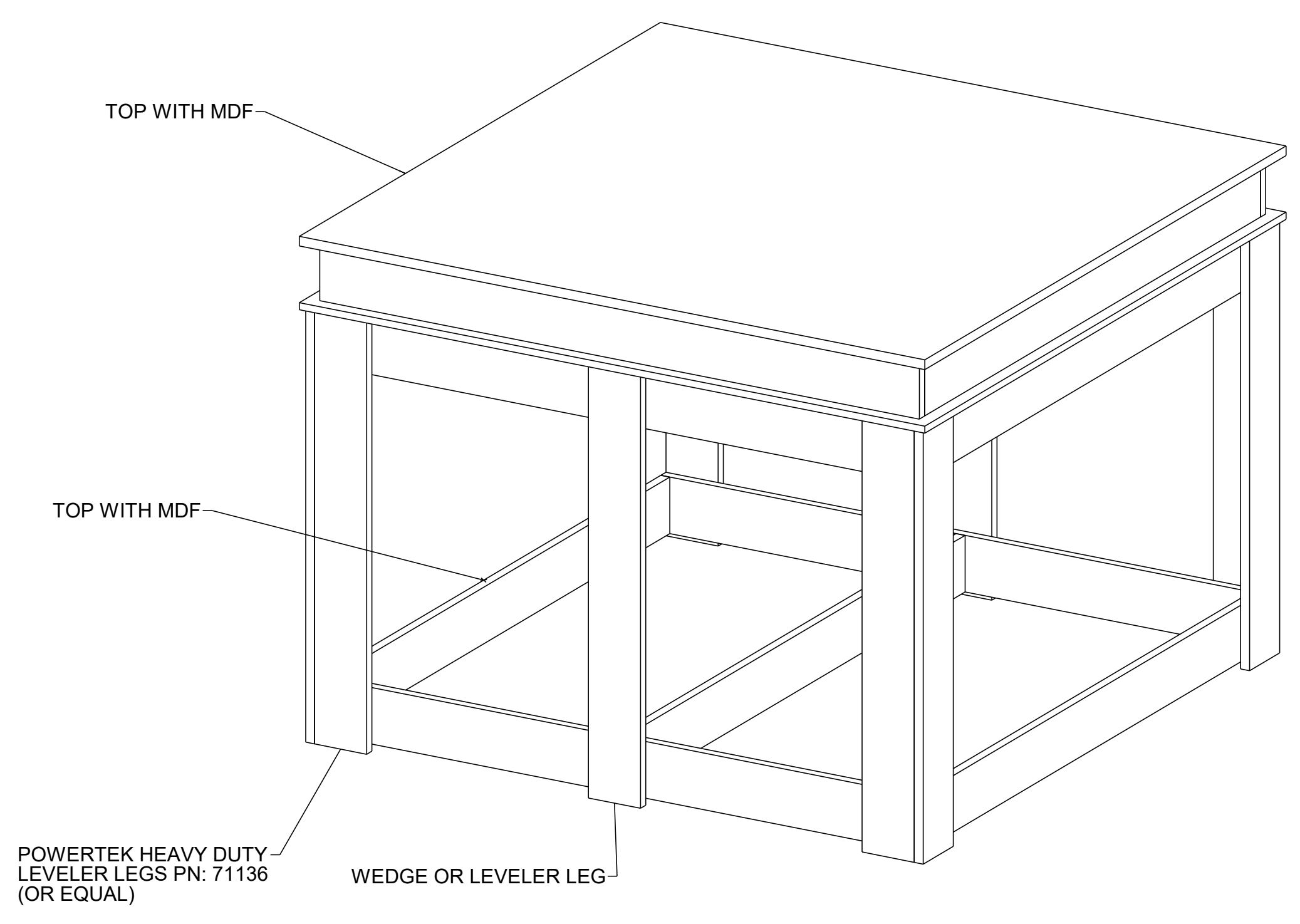
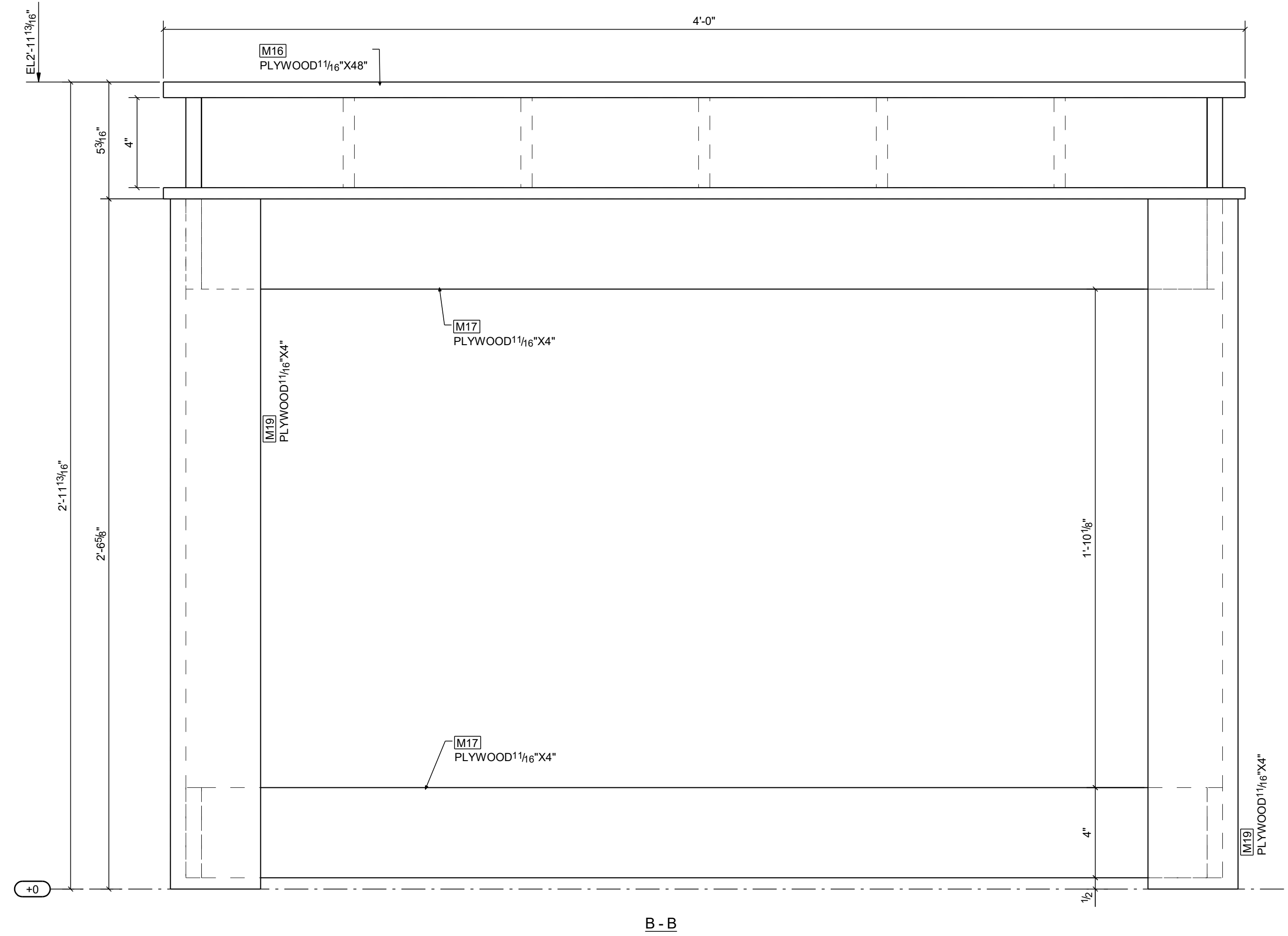
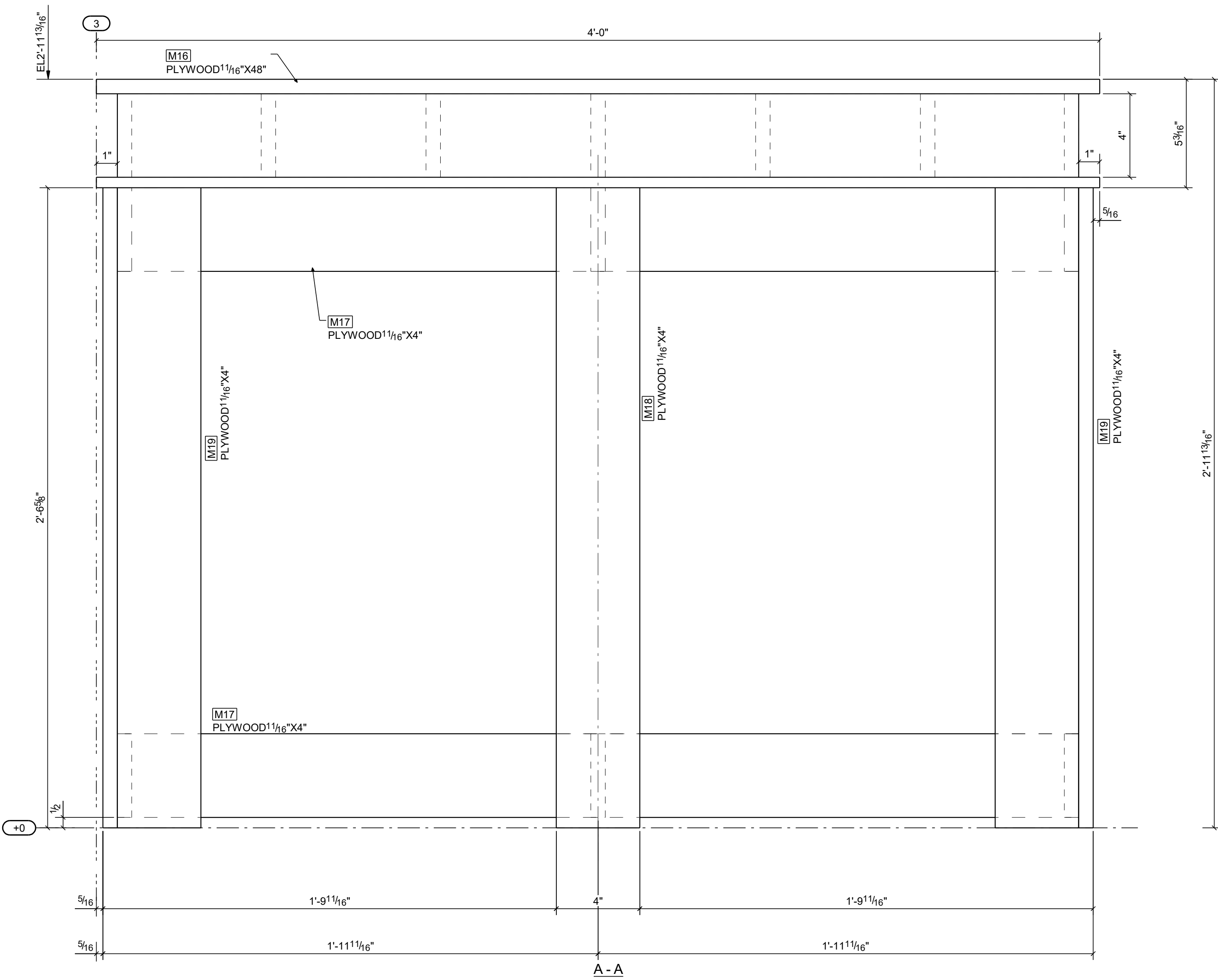

- GENERAL NOTES:
- WORKS WITH LONGMILL 30X30
 - TIGHTBOND III FOR TORSION BOX TOP, NO NAILS OR SCREWS REQUIRED IF TIGHTBOND III IS USED.
 - T&G LEG JOINT IS OPTIONAL, GLUE JOINT WILL ALSO WORK
 - ADJUST LEG LENGTH AND BOTTOM SKIRT AS REQUIRED FOR OPTIMAL WORKING HEIGHT
 - AS IS-NO GUARANTEE-FREE FOR PERSONAL USE

3D STEEL DETAILING, LLC
 8667 S. ZEPHYR ST.
 LITTLETON, CO. 80128
 PHONE: (303) 482-2733

STRUCTURE: LONGMILL TORSION BOX TOP
 LOCATION: LITTLETON, CO
 CUSTOMER: RLW
 ARCH. / EOR: RLW
 REF: LONGMILL TABLE
 DRAWN BY: RLW DATE: 07/29/2020
 CHECKED BY: JSG DATE: 07/29/2020

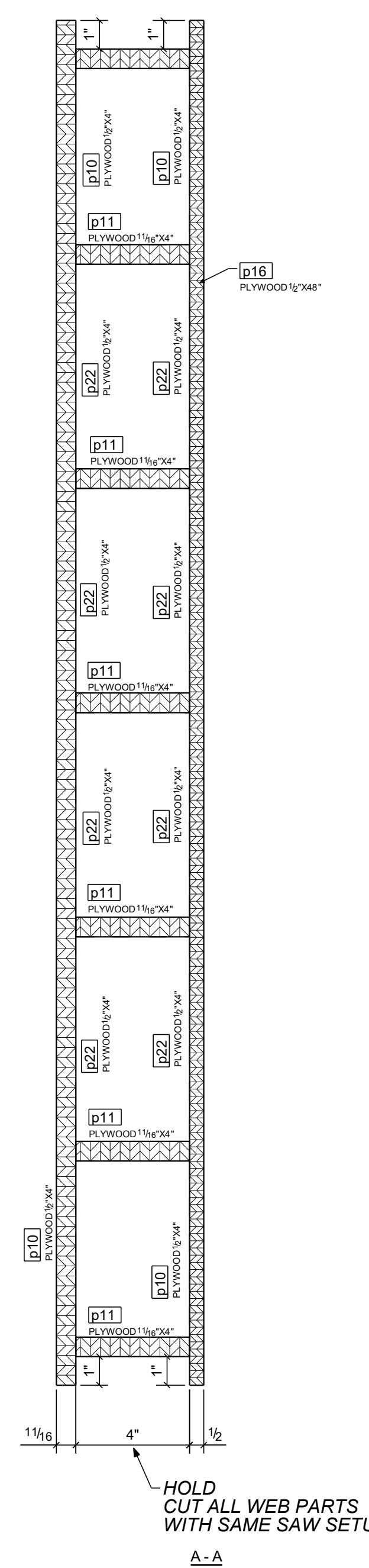
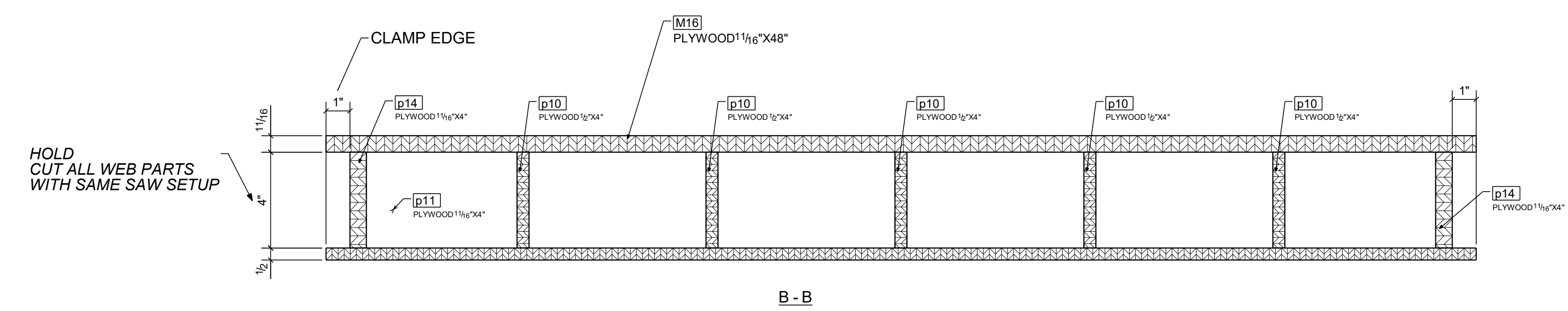
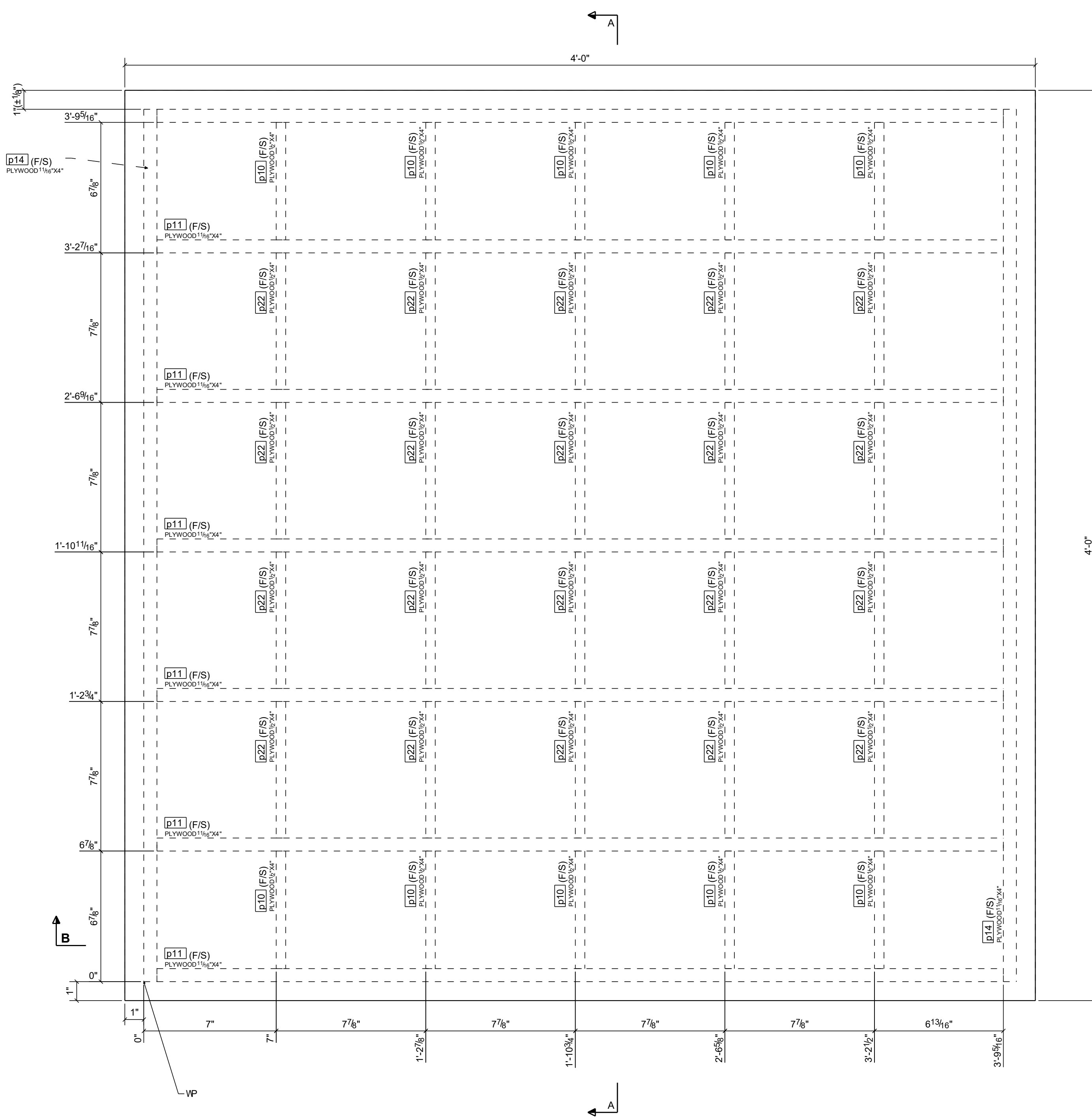

ONE LONGMILL TORSION TOP MK M16

QTY	SHIP	TEMP	DESCRIPTION	LENGTH	MATERIAL	NOTE	WEIGHT ea
1	M16		LONGMILL TORSION TOP	4'-0"	PLYWOOD		69.03
1		p9	PLYWOOD11/16"X48"	4'-0"	PLYWOOD		25.67
10		p10	PLYWOOD12"X44"	6 3/16"	PLYWOOD		0.20
7		p11	PLYWOOD11/16"X44"	3'-8 5/8"	PLYWOOD		1.99
2		p14	PLYWOOD11/16"X44"	3'-10"	PLYWOOD		2.08
1		p16	PLYWOOD12"X48"	4'-0"	PLYWOOD		18.67
20		p22	PLYWOOD1/2"X44"	7 3/16"	PLYWOOD		0.23
TOTAL WEIGHT =							69.03

REV	DATE	REMARKS
0	7/29/2020	For Fabrication
1		REF: LONGMILL TABLE
2		MATERIAL: A36 U.N.O.
3		HOLDS U.N. BOLTS:
4		WELDS: E70XX LH
5		SURFACE PREP:

3D STEEL DETAILING, LLC
 8667 S. ZEPHYR ST.
 LITTLETON, CO. 80128
 PHONE: (303) 482-2733

STRUCTURE: LONGMILL TORSION BOX TOP
 LOCATION: LITTLETON, CO
 CUSTOMER: RLW
 DRAWN BY: RLW DATE: 07/29/2020
 CHECKED BY: JSG DATE: 07/29/2020
 SHEET DESCRIPTION: LONGMILL TORSION TOP
 JOB NUMBER: 2020-1 DRAWING NUMBER: M16

CITY/ST	SEQUENCE DESCRIPTION	GRID LOC.	ELEV.
SHIP MARK M16			
1	TORSION BOX	1348	2-11'13/16

TOTAL QTY	UNIT QTY	BOLTS	LENGTH	SHOP/SITE
SHIP MARK M17				

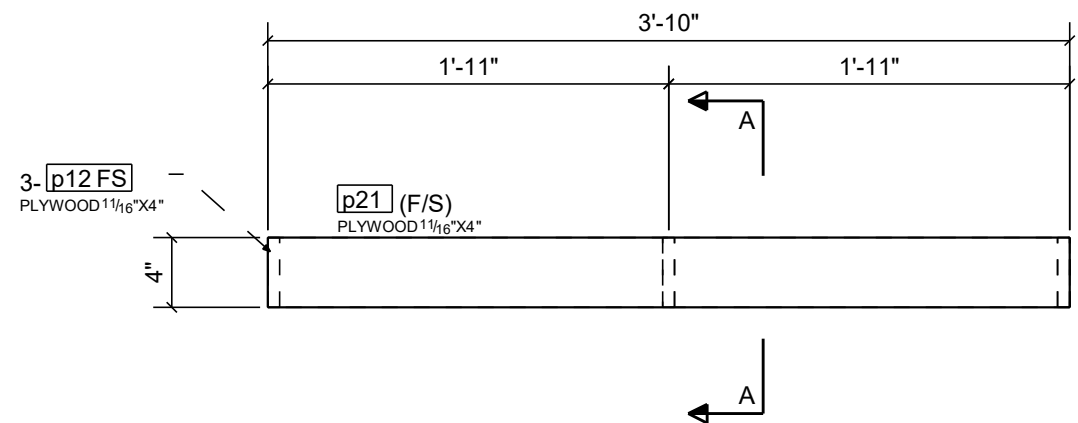
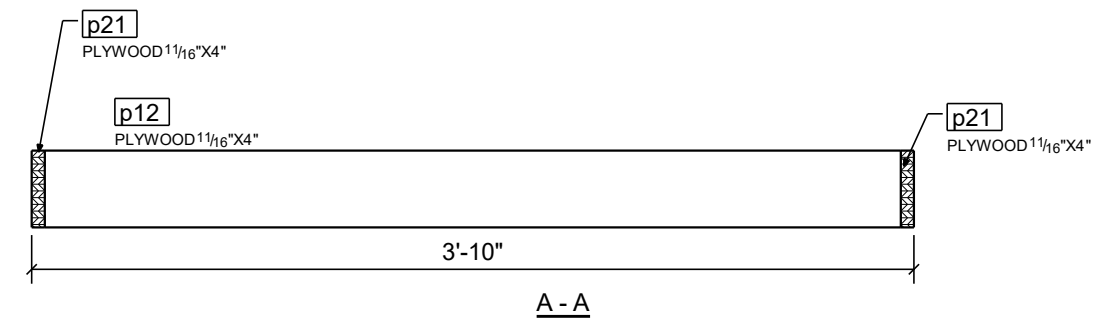
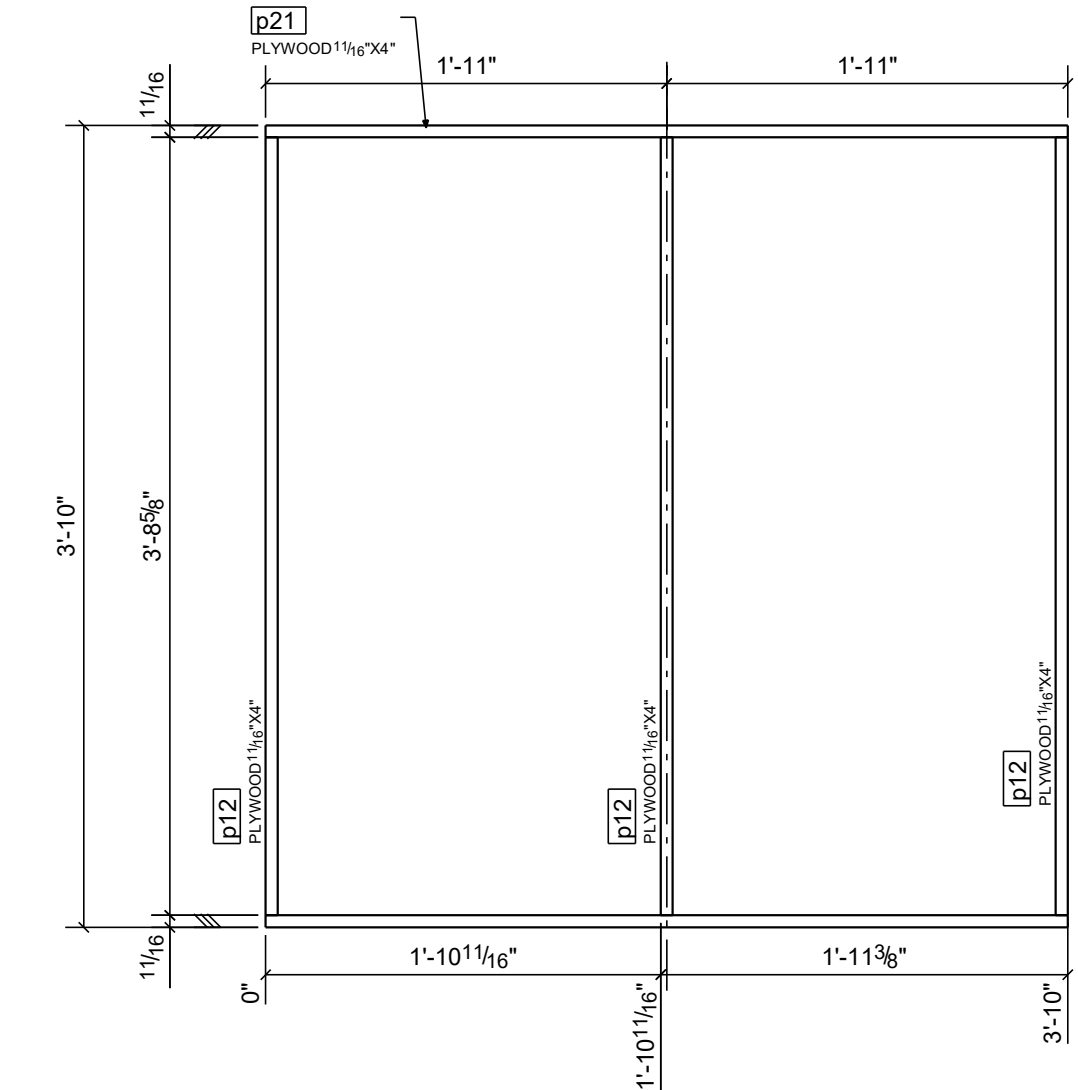

2 SKIRTS MK M17

BILL OF MATERIAL						
QTY	SHIP	TEMP	DESCRIPTION	LENGTH	MATERIAL	WEIGHT ea
2	M17		SKIRT			10.06
4		p21	PLYWOOD 1 1/16" X 4"	3'-10"	PLYWOOD	2.05
6		p12	PLYWOOD 1 1/16" X 4"	3'-8 5/8"	PLYWOOD	1.99
TOTAL WEIGHT =						20.13

QTY	SEQ.	SEQUENCE DESCRIPTION	GRID LOC.	ELEV.
SHIP MARK M17				
1	10	TORSION BOX	3-4A-B	2'-6 5/8"
1	10	TORSION BOX	3-4A-B	4 1/2"

REV	DATE	REMARKS
0	7/29/2020	For Fabrication

REF: LONGMILL TABLE
MATERIAL: A36 U.N.O.
HOLES U.N.: BOLTS:
WELDS: E70XX LH
SURFACE PREP:
PAINT NOTE:

3D STEEL DETAILING, LLC
8667 S. ZEPHYR ST.
LITTLETON, CO. 80128
PHONE: (303) 482-2733

STRUCTURE: LONGMILL TORSION BOX TOP
LOCATION: LITTLETON, CO
CUSTOMER: RLW
DRAWN BY: RLW DATE: 07/29/2020
CHECKED BY: JSG DATE: 07/29/2020
SHEET DESCRIPTION: SKIRT

JOB NUMBER: **2020-1** DRAWING NUMBER: **M17**

TOTAL QTY	UNIT QTY	BOLTS	LENGTH	SHOP/SITE
SHIP MARK M18				

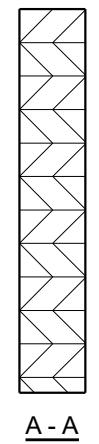
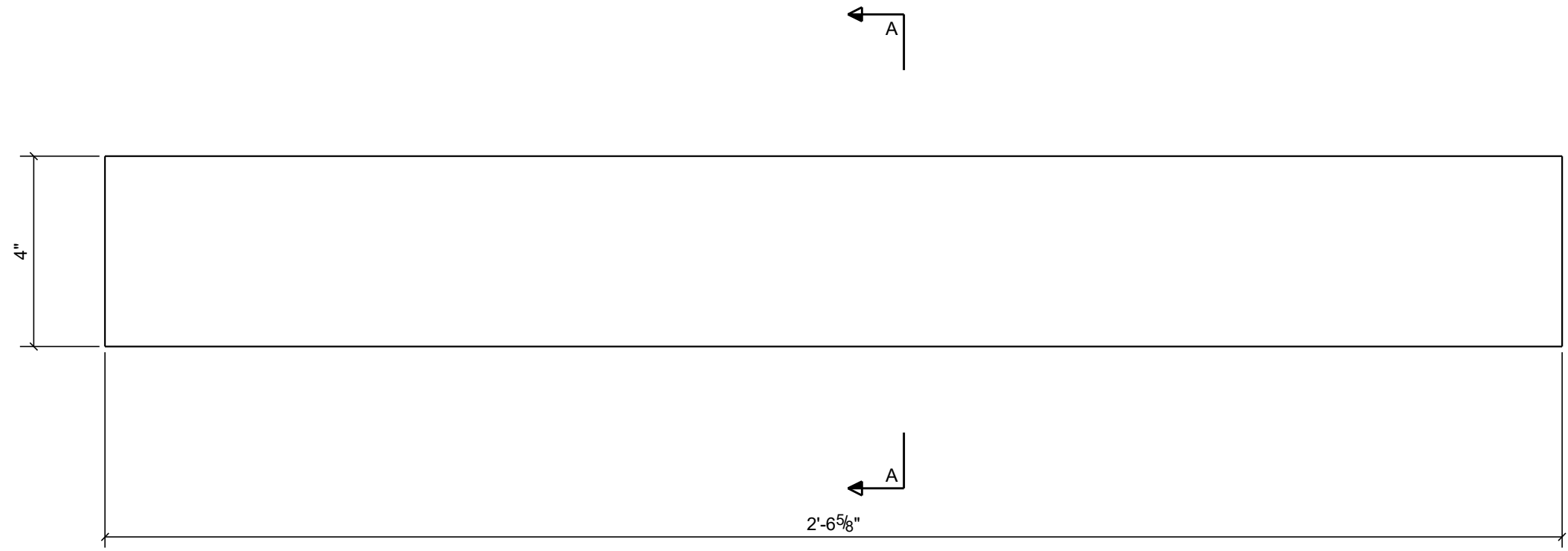

2 LEGS MK M18

BILL OF MATERIAL

QTY	SHIP	TEMP	DESCRIPTION	LENGTH	MATERIAL	NOTE	WEIGHT ea
2	M18		LEG				1.36
2			PLYWOOD 11/16" X 4"	2'-6 5/8"	PLYWOOD		1.36
TOTAL WEIGHT =							2.73

0	7/29/2020	For Fabrication
REV	DATE	REMARKS
REF: LONGMILL TABLE		
MATERIAL: A36 U.N.O.		
HOLES U.N.:	BOLTS:	
WELDS: E70XX LH		
SURFACE PREP:		
PAINT NOTE:		

3D STEEL DETAILING, LLC
 8667 S. ZEPHYR ST.
 LITTLETON, CO. 80128
 PHONE: (303) 482-2733

STRUCTURE: LONGMILL TORSION BOX TOP	
LOCATION: LITTLETON, CO	
CUSTOMER: RLW	DATE: 07/29/2020
DRAWN BY: RLW	CHECKED BY: JSG
DATE: 07/29/2020	
SHEET DESCRIPTION: LEG	
JOB NUMBER	DRAWING NUMBER
2020-1	M18

QTY	SEQ.	SEQUENCE DESCRIPTION	GRID LOC.	ELEV.
2	10	TORSION BOX	3/4A-B	2'-6 5/8"

TOTAL QTY	UNIT QTY	BOLTS	LENGTH	SHOP/SITE
SHIP MARK M19				

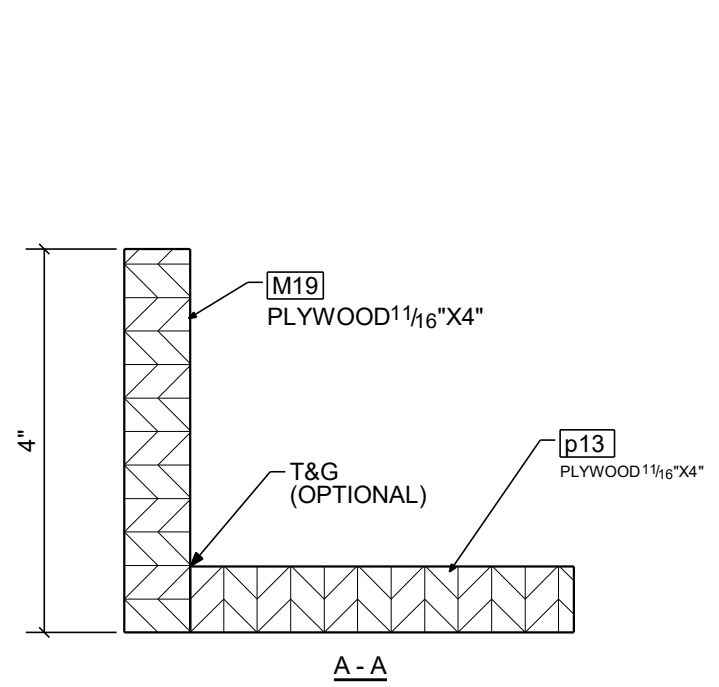
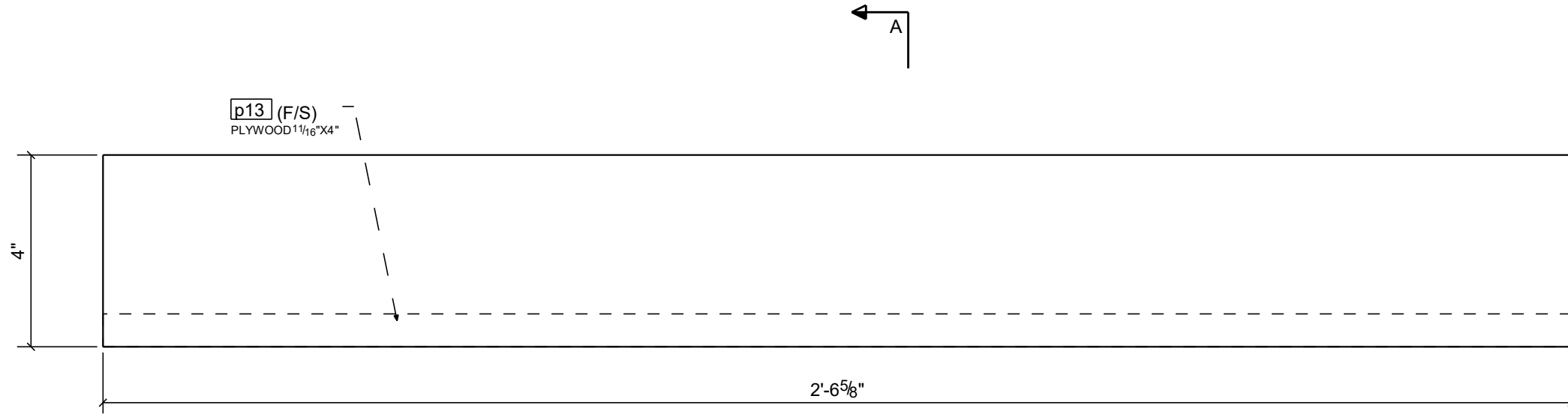

4 LEGS MK M19

BILL OF MATERIAL

QTY	SHIP	TEMP	DESCRIPTION	LENGTH	MATERIAL	NOTE	WEIGHT ea
4	M19		LEG				2.73
8		p13	PLYWOOD 1 1/16" X 4"	2'-6 5/8"	PLYWOOD		1.36
TOTAL WEIGHT =							10.92

0	7/29/2020	For Fabrication
REV	DATE	REMARKS
REF: LONGMILL TABLE		
MATERIAL: A36 U.N.O.		
HOLES U.N.:	BOLTS:	
WELDS: E70XX LH		
SURFACE PREP:		
PAINT NOTE:		

3D STEEL DETAILING, LLC
 8667 S. ZEPHYR ST.
 LITTLETON, CO. 80128
 PHONE: (303) 482-2733

STRUCTURE: LONGMILL TORSION BOX TOP	
LOCATION: LITTLETON, CO	
CUSTOMER: RLW	
DRAWN BY: RLW	DATE: 07/29/2020
CHECKED BY: JSG	DATE: 07/29/2020
SHEET DESCRIPTION: LEG	
JOB NUMBER	DRAWING NUMBER
2020-1	M19